

OPERATION INSTRUCTIONS

Parts List



Hand Pallet Truck

Note: Owner and operator MUST read and understand these operating instructions before using this pallet truck.

ATTENTION:

1. The waste packages should be sorted and put into solid dustbins according to the materials and be collected disposal by local special environment protection bureau. To avoid pollution, it's forbidden to throw away the wastes randomly.
2. To avoid leaking during the use of the products, the user should prepare some absorbable materials (scraps of wooden or dry duster cloth) to absorb the leaking oil in time. To avoid second pollution to the environment, the used absorbable materials should be handed in to special departments in terms of local authorities.

Thank you for choosing our pallet trucks. For your safety and correct operation, please carefully read the manual before use.

NOTE: All of the information reported herein is based on data available at the time of printing. The factory reserves the right to modify its own products at any time without notice or liability in any sanctions. Please verify with the factory for possible updates and changes .

1. GENERAL SPECIFICATIONS

Capacity (kg)	2000
Maximum Fork Height (mm)	200(or190)
Minimum Fork Height (mm)	85(or75)
Fork Length (mm)	1150
Width Overall Forks (mm)	450 / 520 / 550 / 685
Individual Fork Width (mm)	160
Load Wheel Diameter (mm)	Ø 80x70(or Ø 74x70) Nylon, Polyurethane
Steering Wheel Diameter (mm)	Ø 200(or Ø 180) Nylon, Polyurethane, Rubber

Special fork lengths are available in 800, 900, 950, 1000, 1220, 1500, 2000 mm.

Materials and specifications are subject to change without notice.

2. ATTACHING HANDLE TO PUMP UNIT

2.1 Remove 3 bolts (D611) from the handle bracket (D151).

2.2 Set handle (D610A, D610B or D610AS) on the bracket (D151), notice to allow the chain (D612) and the adjusting bolts (D614) assembly to pass through the hole in the center of the bracket (D151) and shaft (D153).

2.3 Insert the 3 bolts (D611) through the handle into the bracket (D151), then tighten them securely.

2.4 Raise the lever plat (D132) and insert the adjusting bolt (D614) into the front slot, keeping the adjusting nut (D615) on the under side of the lever plat (D132).

3. ADJUSTING RELEASE DEVICE

On the draw-bar of this pallet truck, you can find the control handle (D608 or D608S) which can be adjusted in three positions :

Raise - handle down

Drive - handle in center position

Lower - handle up, the lever moves back the drive position when released.

If however they have been changed, you can adjust according to the following steps:

3.1 If the forks elevate while pumping in the **DRIVE** position, turn the adjusting nut (D615) on the adjusting bolt (D614) or adjusting screw (D133) clockwise until pumping action does not raise the forks and the **DRIVE** position functions properly.

3.2 If the forks descend while pumping in the **DRIVE** position, turn the nut (D615) or adjusting screw (D133) counter-clockwise until the forks do not lower.

3.3 If the forks do not descent when the control handle (D608 or D608S) is in the **LOWER** position, turn the nut (D615) or adjusting screw(D133) clockwise until raising the control handle(D608 or D608S) lowers the forks. Then check the **DRIVE** position according to item 3.1 and 3.2 to be sure

the nut (D615) or adjusting screw (D133) is in the proper position.

3.4 If the forks do not elevate while pumping in the **RAISE** position, turn the nut (D615) or adjusting screw(D133) counter-clockwise until the forks elevate while pumping in the **RAISE** position. Then check the **LOWER** and **DRIVE** position according to item 3.1, 3.2 and 3.3.

4. MAINTENANCE

Your pallet truck is largely maintenance-free.

4.1 OIL

Please check the oil level every six months. The oil capacity is about 0.3lt. Use the hydraulic type oil according to temperature scale below.

Temperature	Oil
-20°C~+40°C	L-HV46 Hydraulic oil

4.2 EXPELING AIR FROM THE PUMP UNIT

The air may come into the hydraulic oil because of transportation or pump in upset position. It can cause the forks unable to elevate while pumping while in the **RAISE** position. The air may escape in the following way: let the control handle (D608 or D608S) on the **LOWER** position, then move the handle (D610A, D610B or D610AS) up and down for several times.

4.3 DAILY CHECK AND MAINTENANCE

Daily check of the pallet truck can limit wear as much as possible. Special attention should be paid to wheels, axles, thread, rags, etc. It may block the wheels. The forks should be unloaded and lowered in the lowest position when the job is over.

4.4 LUBRICATION

Use motor oil or grease to lubricate all moveable parts.

5. GUIDE TO SAFETY OPERATIONS

For safe operation of the Hand Pallet Truck, please read all warning signs and instructions here and on the pallet truck prior to use.

- 5.1 Do not operate the pallet truck unless you are familiar with it and have been trained or authorized to do so.
- 5.2 Do not operate the truck unless you have been trained and authorized. Pay special attention to the wheels, the handle assembly, the forks and the lower control.
- 5.3 Do not use the truck on sloping ground.
- 5.4 Never place any part of your body in the lifting mechanism or under the forks or load. Do not carry passengers.
- 5.5 It is advisable that operators should wear gloves and safety shoes.
- 5.6 Do not handle unstable or loosely stacked loads.
- 5.7 Do not overload the truck.
- 5.8 Always place loads centrally across the forks and not at the end of the forks (See Fig. 2).
- 5.9 The capacity of the truck assumes an evenly distributed load with the center of the load being

at the halfway point of the length of the forks.

5.10 Make sure that the length of the forks matches the length of the pallet.

5.11 Lower the forks to the lowest height when the truck is not being used.

5.12 In other specific conditions, the operators should take extra care in operating the truck.

6. TROUBLES SHOOTING

No	Trouble	CAUSE	ACTION
1	The forks can not be lifted up to the maximum height.	- The hydraulic oil is not enough.	- Pour in the oil.
2	The forks can not be lifted up.	<ul style="list-style-type: none"> ● Without hydraulic oil ● The oil has impurities ● The nut (D615) is too high or the screw (D133) is too close, keep the pumping valve open ● Air come into the hydraulic oil 	<ul style="list-style-type: none"> ● Fill in the oil ● Change the oil ● Adjust the nut (D615) or the screw (D133) .(see item 3.4) ● Banish the air.(see item 4.2)
3	The forks can not be lowered.	<ul style="list-style-type: none"> ● The piston rod (D147) or pump body is deformed resulting from partial loading slanting to one side or over-loading. ● The fork was kept in the high position for long time with piston rod bared to arise in rusting and jamming of the rod. ● The adjusting nut (D615) or the screw (D133) is not in the correct position 	<ul style="list-style-type: none"> ● Replace the piston rod (D147) or pump body ● Keeping the fork in the lowest position if not using, and pay more attention to lubricate the rod ● Adjust the nut (D615) or the screw (D133). (see item 3.3)
4	Leaks	<ul style="list-style-type: none"> ● Sealing parts worn or damaged ● Some part cracked or worn into small 	<ul style="list-style-type: none"> ● Replace with the new one ● Replace with the new one
5	The forks towers without the release valve working.	<ul style="list-style-type: none"> ● The impurities in the oil cause the release valve to be unable to close tight. ● Some parts of hydraulic system is cracked or bored. ● Air come into the oil. ● Sealing parts worn or damaged ● The adjusting nut (D615) or the screw (D133) is not in the correct position 	<ul style="list-style-type: none"> ● Replace with new oil ● Inspect and replace the waste parts ● Banish the air.(See item 4.2) ● Replace with the new one ● Adjusting the nut (D615) or the screw (D133). (See item 3.2)

***NOTE: DO NOT ATTEMPT TO REPAIR THE PALLET TRUCK UNLESS YOU ARE TRAINED AND AUTHORIZED TO DO SO.**

Fig.1

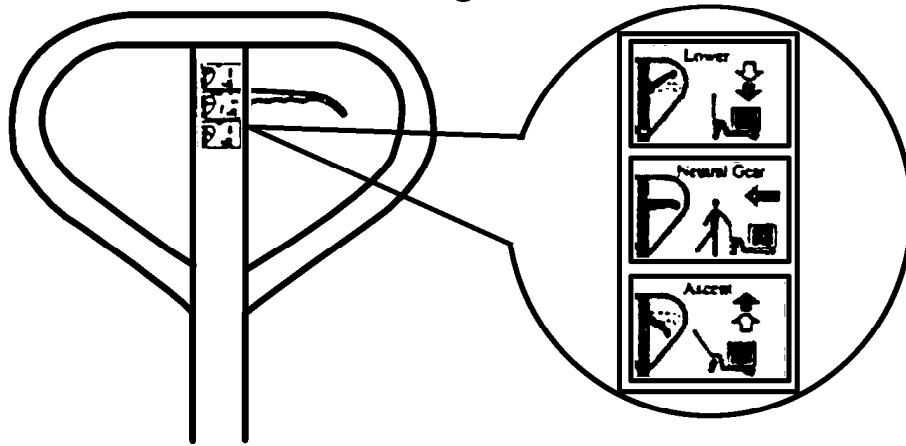
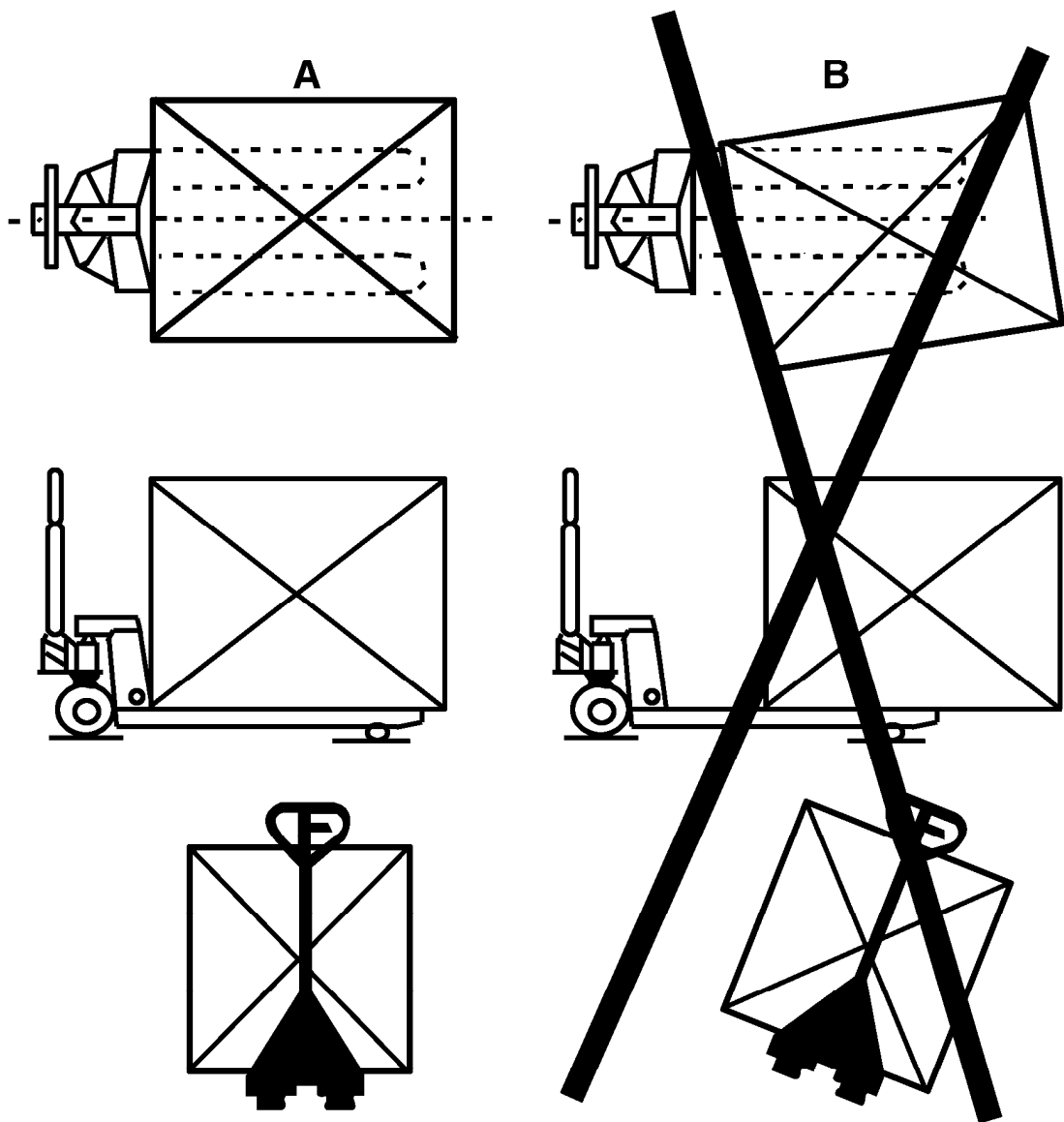

Fig.2



No.	Description	Qty.	No.	Description	Qty.		
1	D601	Spring	1	9	D609	Pull Board	1
2	D602	Blade Spring	1	10	D610B	Handle	1
3	D603	Roller	1	11	D611	Screw	3
4	D604	Elastic Pin	1	12	D612	Chain	1
5	D605	Elastic Pin	1	13	D613	Pin	1
6	D606	Elastic Pin	1	14	D614	Adjusting Bolt	1
7	D607	Elastic Pin	1	15	D615	Adjusting Nut	1
8	D608	Control Handle	1	16	D616	Elastic Washer	3
17	D101	Pump Piston Rod	1	46	D132	Lever Plat	1
18	D102	Washer	1	47	D133	Adjusting Screw	1
19	D103	Spring	1	48	D134	Nut	1
20	D104	Dust Ring	1	49	D135	O – Ring	1
21	D105	Y – Seal	1	50	D136	Axle Sleeve	1
22	D106B	Screw	1	51	D137	Adjusting Bolt	1
23	D107B	O – Ring	1	52	D139	Spindle of Safety Valve	1
24	D108	Spring	1	53	D140	Spring	1
25	D109	Spindle of Pumping Valve	1	54	D141	O – Ring	1
26	D110B	Seat of Pumping Valve	1	55	D142	Screw	1
27	D111B	O – Ring	1	56	D143	O – Ring	1
28	D112	Steel Ball	1	57	D144	Y – Seal	1
29	D113	Base of Pump	1	58	D145	Elastic Pin	1
30	D115	Elastic Pin	1	59	D146	Steel Ball	1
31	D116	Steering Wheel	2	60	D147	Piston Rod	1
32	D117D	Shaft of Steering Wheel	1	61	D148	Dust Ring	1
33	D118	Thrust Plate	1	62	D149	Screw	1
34	D119	Oil – holder	1	63	D150	Shaft	1
35	D120	Retaining Ring	1	64	D151	Bracket	1
36	D121	Cover of Bearing	1	65	D152	Pressure Roller	1
37	D122	Bearing	1	66	D153	Shaft	1
38	D123	Elastic Pin	2	67	D154	Elastic Pin	1
39	D124	Dust Cover	2	68	D155	Elastic Pin	1
40	D125D	Retaining ring	2	69	D156	Bushing	1
41	D126D	Tab Washer	2	70	D157	Seal Washer	1
42	D127	Bearing	4	71	D158	Bushing	2
43	D129	Spring	1	72	D159B	Sleeve	1
44	D130	Strike Pin	1	73	D160B	Screw	1
45	D131	O – Ring	2				
74	D201	Screw	1	90	D217#	Shaft for Roller	4
75	D202	Oil - holder	1	91	D218	Fork Frame	1
76	D203	Rock – arm	1	92	D219	Washer	8 or 4
77	D204	Elastic Pin	1	93	D220	Bearing	8 or 4
78	D205	Retaining Ring	2	94	D221#	Loading Roller	4
79	D206D	Joint	2	95	D222#	Linking Plate	4
80	D207	Shaft	2	96	D223	Elastic Pin	8 or 2
81	D208D	Pushing Rod	2	97	D224	Bushing	4
82	D209D	Nut	2	98	D225	Bushing	2
83	D210	Pin	2	99	D226	Bolt	2
84	D211	Shaft	1	100	D227	Enter Roller	2
85	D212	Shaft	2	101	D228	Nut	2
86	D213	Elastic Pin	2	102	D229*	Loading Roller	2
87	D214	Shaft	2	103	D230*	Shaft for Roller	2
88	D215	Frame of Roller	2	104	D231	Washer	2
89	D216	Elastic Pin	2	105	D232	Washer	4

(Note # --For Tandem wheel, * --For single wheel)

List of Assembly

No.	Parts No.	Description	List of Assembly	Qty.
1	DF20-01	Handle Ass'y	D601, D602, ..., D610B, D612, ..., D615	1
2	DF20-02-	Control handle kit	D603, D605, D608	1
3	DF20-03	Chain Ass'y	D609, D612, D613, D614, D615	1
4	DF20-04	Load Roller Ass'y(Single Type)	D220, D220, D229	2
5	DF20-05	Load Roller Ass'y(Tandem Type)	D220, D220, D221	4
6	DF20-06	Steering Wheel Ass'y	D116, D127, D127	2
7	DF20-07	Seal Kit of Pump Unit	D104, D105, D107B, D111B, D131, D131, D135, D141, D143, D144, D148, D157	1
8	DF20-08	Bracket Ass'y	D150, D151, D152, D154, D156	1
9	DF20-09	Pump Ass'y	D101, D102, D103, D104, D105, D106B, D107B, D108, D109, D110B, D111B, D112, D113, D129, D130, D131, D132, D133, D134, D135, D136, D137, D139, D140, D141, D142, D143, D144, D145, D146, D147, D148, D149, D150, D151, D152, D153, D154, D155, D156, D157, D158, D159B, D160B	1

Option: Foot Brake

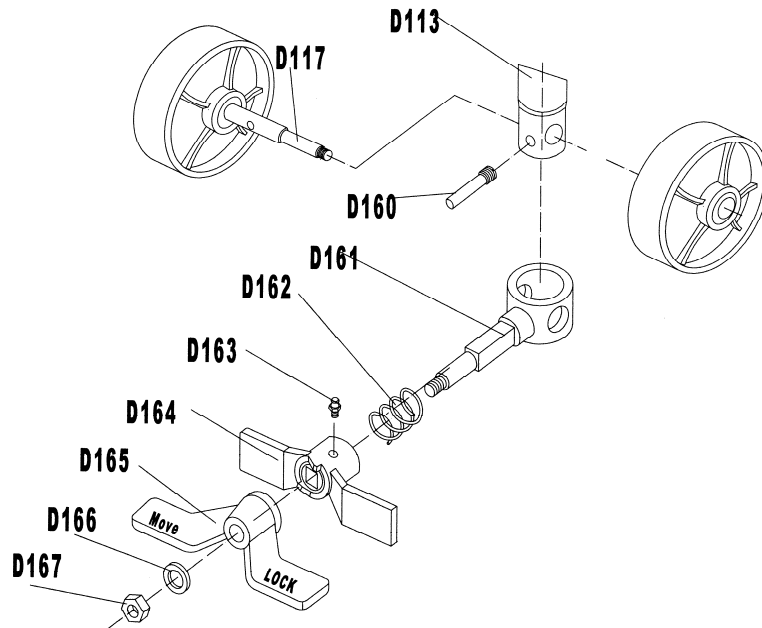

No.	Description	Qty.	No.	Description	Qty.
D117	Shaft of Steering Wheel	1	D163	Oil - Holder	1
D113	Pump Body	1	D164	Brake Plate	1
D160	Pin	1	D165	Pedal	1
D161	Holding Sleeve	1	D166	Washer	1
D162	Spring	1	D167	Nut	1